

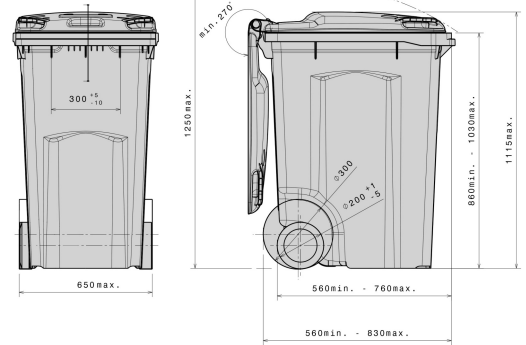

MGBneo Twin-compartment wheeled bin system

340-360 | 50/50



Technical Data

External Dimensions (mm)	A: 590 ±20	B: 880	C: 1115
Volume (l)	340 l		
Material Body / Material Lid	PE/PE		
Holding Capacity (kg)	 136/144 kg		
Available colours	grey, green, blue, yellow, anthracite		

Characteristics

Container corresponds to:	EN840, RAL-GZ 951/1, Directive 2000/14/EG	Extra equipment / Accessories colour clips for marking the compartments noise insulation plugs wheels Ø 200 mm
Travelling gear:	External, wheel Ø 250 mm, rubber tired wheels, wheel axle from tempered, galvanized steel	
Receiver:	Comb lift	
Prepared for transponder:	Yes	

Loading quantities (Pcs / Approximate amount)

On request

Labelling

On the lid, on the body

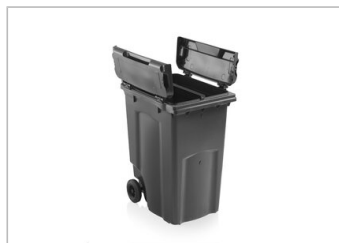

*1 All specifications quoted are subject to change. Craemer reserve the right to make changes to product design and specification.

*2 Extra equipment, accessories, as well as other colors are available at extra cost and on request.