

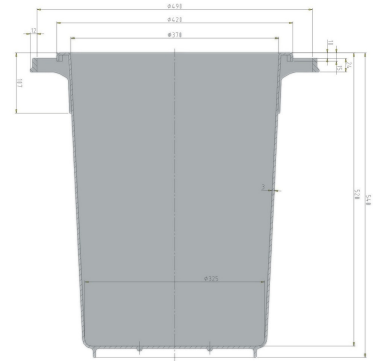

Bin

50 l



Art.-Nr.: 81081100

Technical Data^{*1}

External Dimensions (mm)	Ø 420 x 540	Internal Dimensions (mm)	Ø 370 x 520
Weight (kg)	2,0 kg		
Volume (l)	50 l		
Material	PE		
Load capacity (kg)	Holding Capacity 50kg	Extra Load 105kg	
Stacking height (mm)	When nested 105mm	When stacked 525mm	

Characteristics

Colour: white
 Nestable, stackable with lid
 For temperatures ranging from -30 °C to +40 °C, briefly up to +90 °C
 Resistant to most chemicals and cleaning agents
 Food-safe. HACCP compliant

Options

Lid
 Trolley

Loading quantities (Pcs / Approximate amount)

On request

Labelling

Customised printing and numbering available on request depending on quantity (except trolleys). Position upon consultation.



^{*1} All technical data include characteristic features, which have been tested under specially defined conditions. Varying data may result from different conditions of usage such as loading method, prevailing temperature and length of storage time. All data and specified information are subject to change without notice. Our service team is pleased to be at your disposal to check the special requirements of your individual application.