

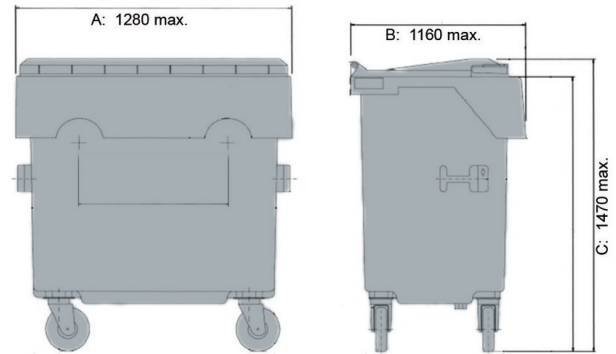

DU Container 660 l - 1,1 m³

1,100 l



Technical Data* ¹			
External Dimensions L x W x H (mm)	Length (mm): 1280 max.	Width (mm): 1160 max.	Height (mm): 1470 max.
Volume (l)	1100 l		
Material Body / Material Lid	Sheet metal, galvanized / Sheet metal, galvanized		
Holding Capacity (kg)	 440kg		
Characteristics		Extra equipment / Accessories* ²	
Travelling gear:	Wheel Ø 200 mm, rubber-tired wheels, 4 guide rollers, 2 wheel stops or central locking system	Glas slot Paper slot Central locking system Lifting grips DIN-trunnion Foot-operated lid opener Fork-lift pockets Oil-sealed welding (sheet metal)	
Receiver:	Diamond receiver		
Prepared for transponder:	Yes		
Loading quantities (Pcs / Approximate amount)			
On request			
Labelling			
On the lid, on the body			

*1 All specifications quoted are subject to change. Craemer reserve the right to make changes to product design and specification.

*2 Extra equipment, accessories, as well as other colors are available at extra cost and on request.